

# EcoPump HP

## Horizontal Piston Pump

### Description

The **EcoPump HP** is an air-driven horizontal piston pump. It has been manufactured and tested according to Dürr's well-proven quality standards. Performance and durability are further distinguishing characteristics in order to meet the highest of demands. With a concealed shaft seal this **EcoPump HP** is primarily designed for paint circulation systems as well as fluid transfer and supply. A horizontal two piston design

guarantees equal thrust on both strokes and a rapid pump change-over with a quick release valve for reduced surge. Its modular design enables easy maintenance and an extensive range of accessories are also available. Typically handled fluids are water and solvent borne paints, varnishes, enamels and lacquers.

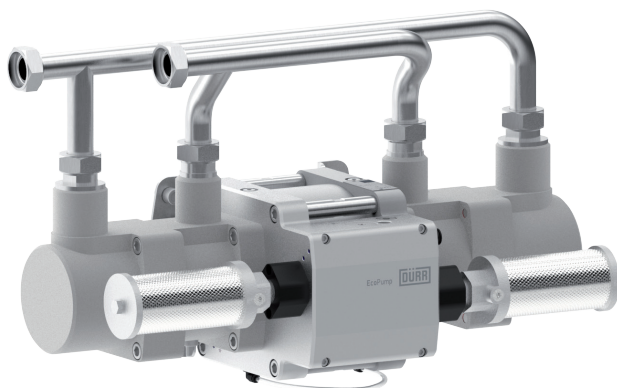

### Customer Benefits

- » Tested according to DIN EN 12162 and well-proven Dürr quality standards
- » Low ice change-over by thermal isolation of the muffler and optimized air flow
- » Four-ball design
- » No exposed shaft seal
- » Lubricant free
- » Horizontal two-piston design guarantees equal thrust on both strokes
- » Rapid pump change-over with quick release valve for reduced surge
- » Cavity free fluid connection (**EcoTube**)
- » Modular pump design, easy to maintain
- » Wide range of accessories available
- » ATEX Ex II 2G IIA T6



